



**AUSTRALIA**

**Mister Hitches  
4000kg 12 STAGE  
ADJUSTABLE  
BALL MOUNT HITCH  
SHORTER SHANK STYLE**

Designed and developed by  
*MISTER HITCHES AUSTRALIA.*

Due to requests from Pajero Sport owners we have now developed a shorter shank version of our ever popular MHABM-5XHDS. The shorter shank is suitable for the shallow towbar receivers of the MM Pajero Sport & Ford Ranger (Pre Next-Gen) This hitch has a 25mm x 75mm ball platform and is one of only a few ball mounts which is suitable for the Stone Stomper under ball bracket. This hitch is fully reversible which gives you 12 mounting adjustments. Dual 10mm strengthening gussets a 5.75mm thick shank wall & H.T. 12.9 grade mounting hardware make this one of the strongest & most versatile hitches on the market.

**Features:**

- G.T.W.: 4000kg T.W.: 400kg
- PIN HOLE TO BALL HOLE: 252mm.
- PIN HOLE TO GUSSET: 60mm.
- PIN HOLE TO END OF SHANK: 40mm.
- 12 ADJUSTABLE POSITIONS. REVERSIBLE SHANK & BALL PLATFORM.
- DROP: 80-186mm RISE: 50-160mm.
- D035 COMPATIBLE.
- 5.75mm THICK WALLED STEEL SHANK, ROBOTIC WELDED FOR STRENGTH.
- DUAL 10mm GUSSETS FOR ADDED STRENGTH.
- HIGH TENSILE 12.9 GRADE BOLTS.
- SEAGUARD MATTE BLACK POWDER COAT FINISH GIVES SUPERIOR CORROSION PROTECTION.
- COMPLIES TO THE TESTING REQUIREMENTS OF ADR62 & AS4177 AUSTRALIAN STANDARDS.



**DO NOT OVERLOAD**

WARNING

**THIS IS ANOTHER QUALITY MISTER HITCHES PRODUCT.  
MADE TO MISTER HITCHES SPECIFICATIONS  
[www.misterhitches.com.au](http://www.misterhitches.com.au)**

**HEAVY DUTY 4000kg  
ADJUSTABLE HITCH  
SHORTER SHANK**

Part No. MHABM-5XHDP

**SUITS THE SHALLOW RECEIVER OF THE MITSUBISHI PAJERO SPORT WITH O.E.M. TOWBAR AND OTHER VEHICLES REQUIRING A SHORTER SHANK**

**PAJERO SPORT**

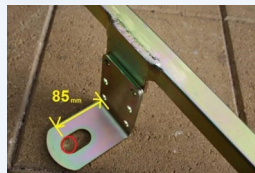
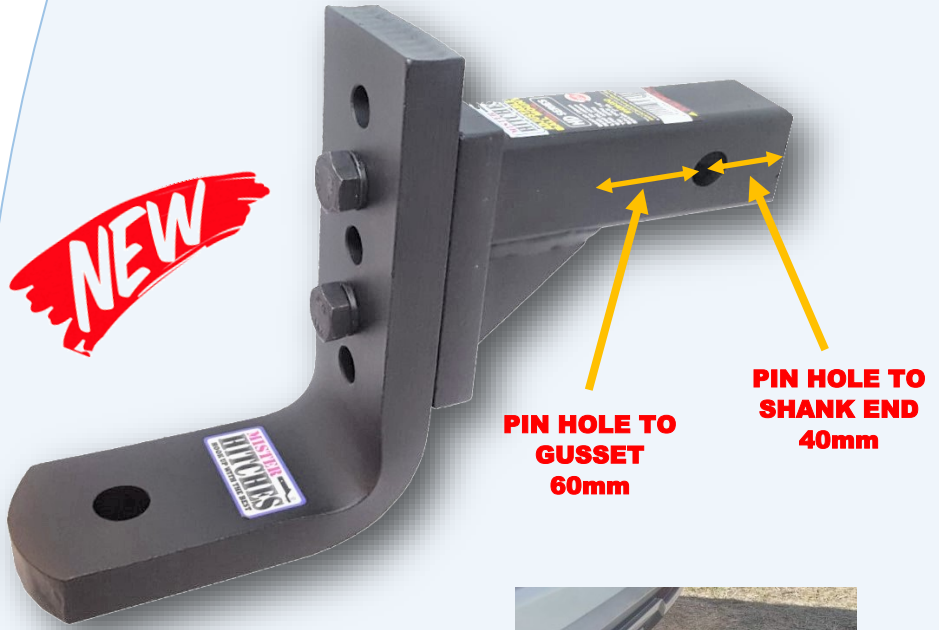

**STONE STOMPER COMPATIBLE**

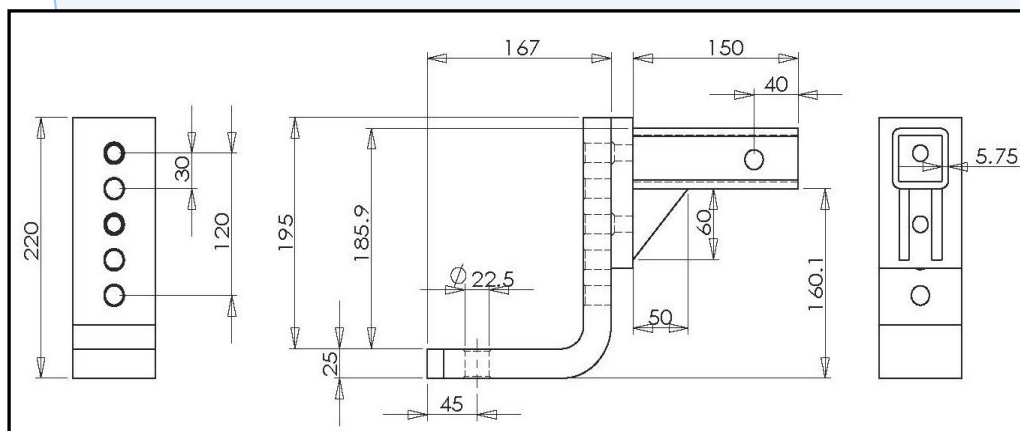
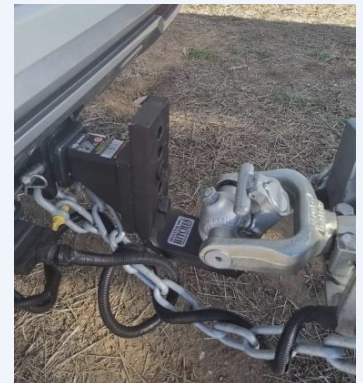

Part No. MHABM-5XHDP  
Barcode: 000006793036  
Weight: 8kg  
Carton: 1pc



INTERTRADE HOLDINGS PTY LTD  
UNIT 1, 2 TIDAL WAY BIBRA LAKE 6163 WA  
TEL: 08 9418 7044  
info@intertradedholdings.com.au  
www.misterhitches.com.au